

ITEM	DESCRIPTION	MATERIAL	REQ'D	DRAWING NUMBER	REMARKS
1	SIDE WALL	ALUMINIUM ALLOY 6082	4	11436-51-A3-NUC	
2	FRONT END PLATE	ALUMINIUM ALLOY 6082	1	11436-52-A3-NUC	
3	REAR END PLATE	ALUMINIUM ALLOY 6082	1	11436-53-A3-NUC	

FRAME TO BE FABRICATED USING THE HOLE AND TWISTED TAG METHOD FOLLOWED BY DIP BRAZING. ONCE BRAZED ALL EXCESS MATERIAL TO BE MACHINED OFF. SIZE AND LOCATION OF HOLES AND TAGS AT THE DISCRETION OF ELECTROBASE RP LTD

MAXIMUM LOAD ON FRAME = 23 Kg

SALT BATH / DIP BRAZING DETAILS:-

ELECTROBASE RP LTD
 7, AVERY WAY
 QUESTOR INDUSTRIAL PARK
 DARTFORD
 KENT
 DA1 1JZ
 TELE:- +44 (0)1322-282460
 FAX:- +44 (0)1322-290518
 http://www.electrobase.co.uk

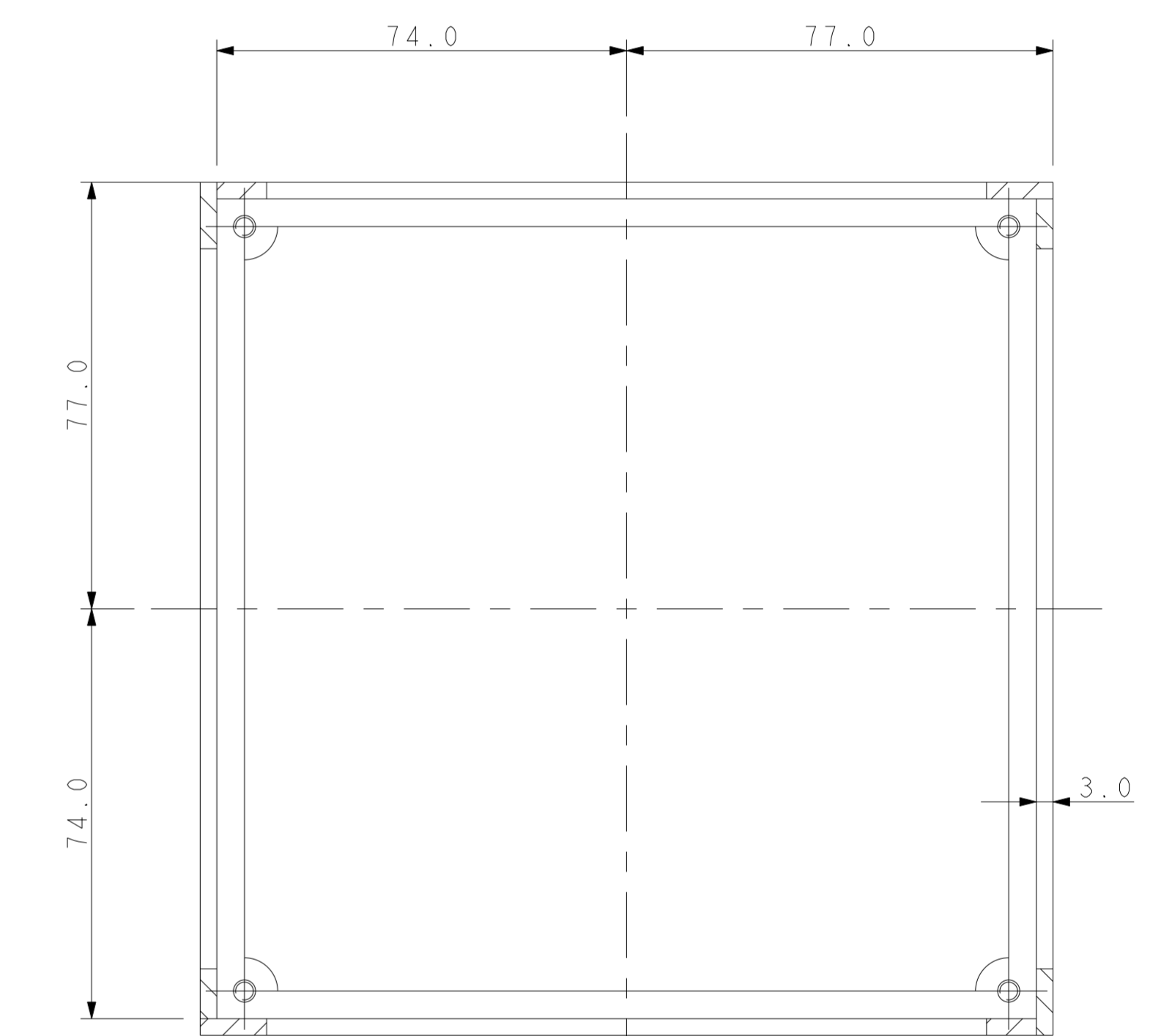
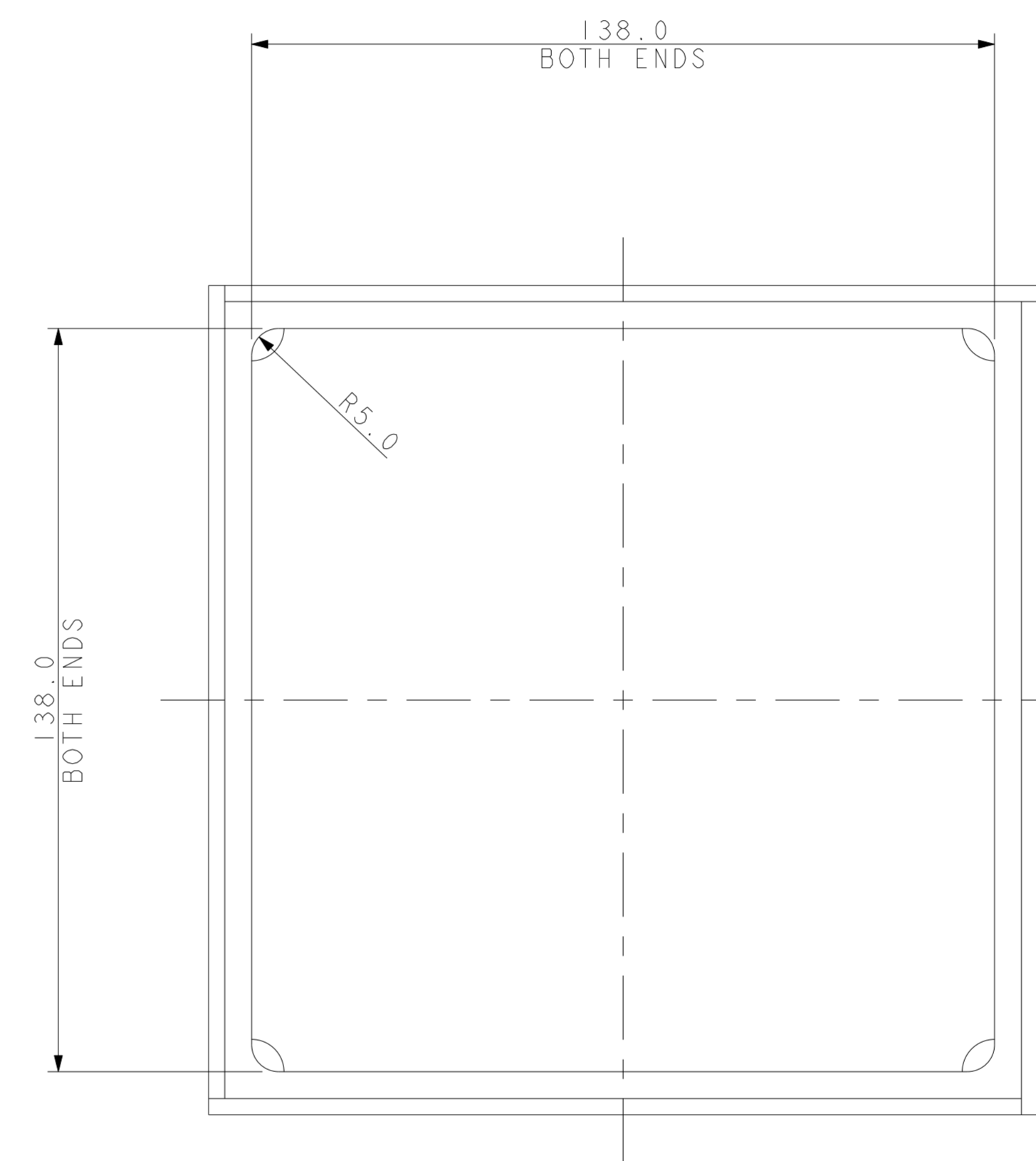
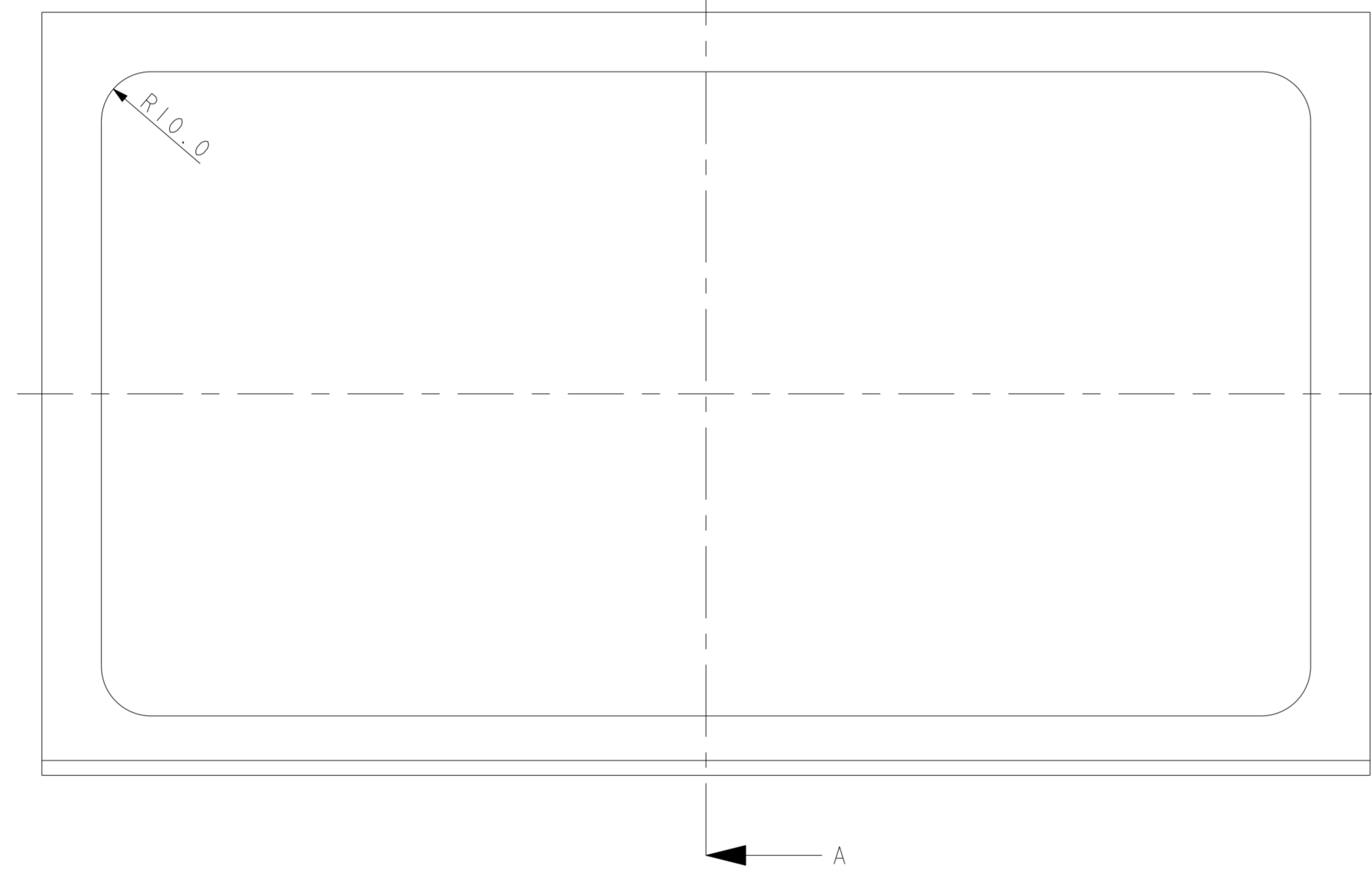
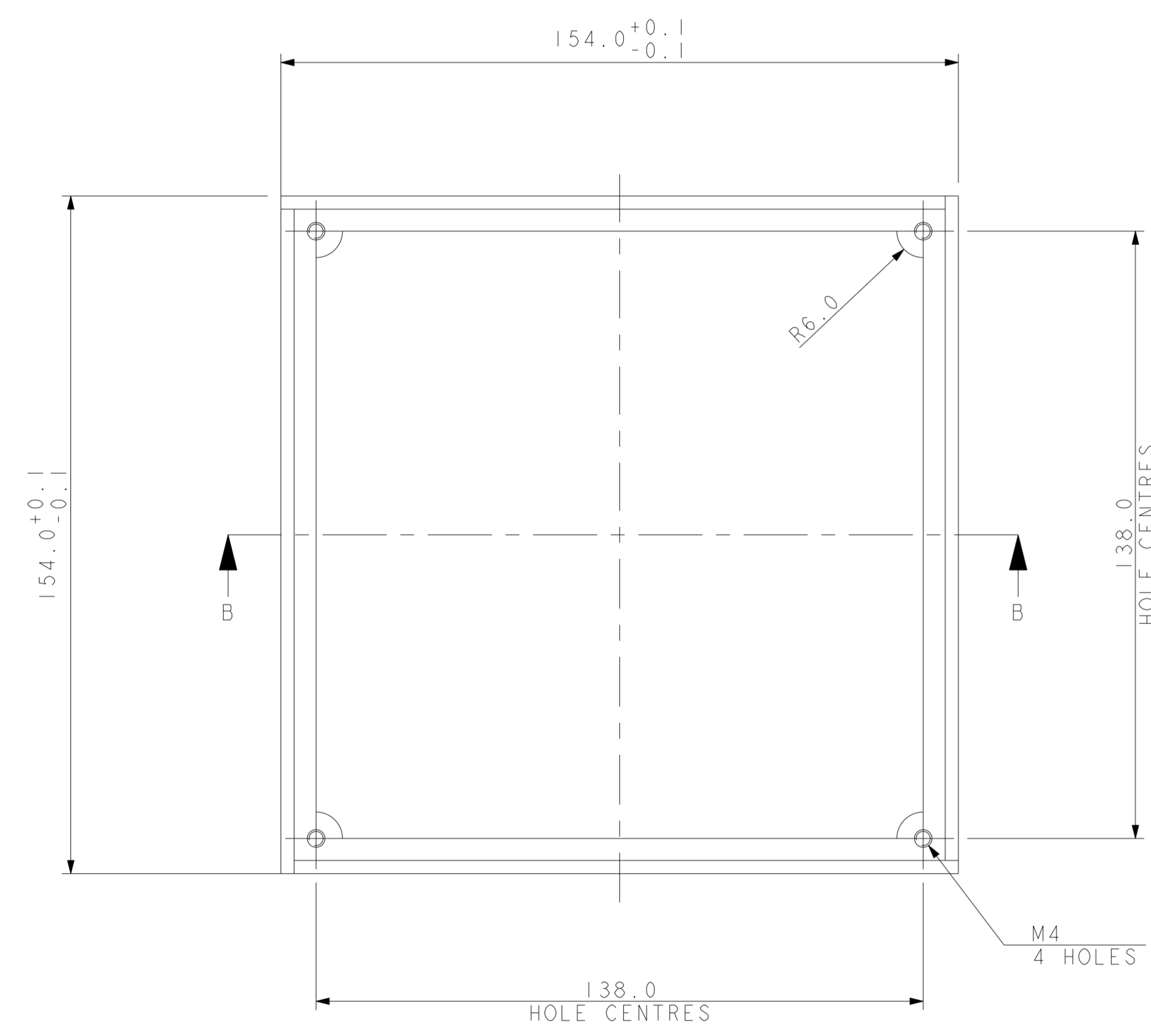

SECTION A-A



SECTION B-B

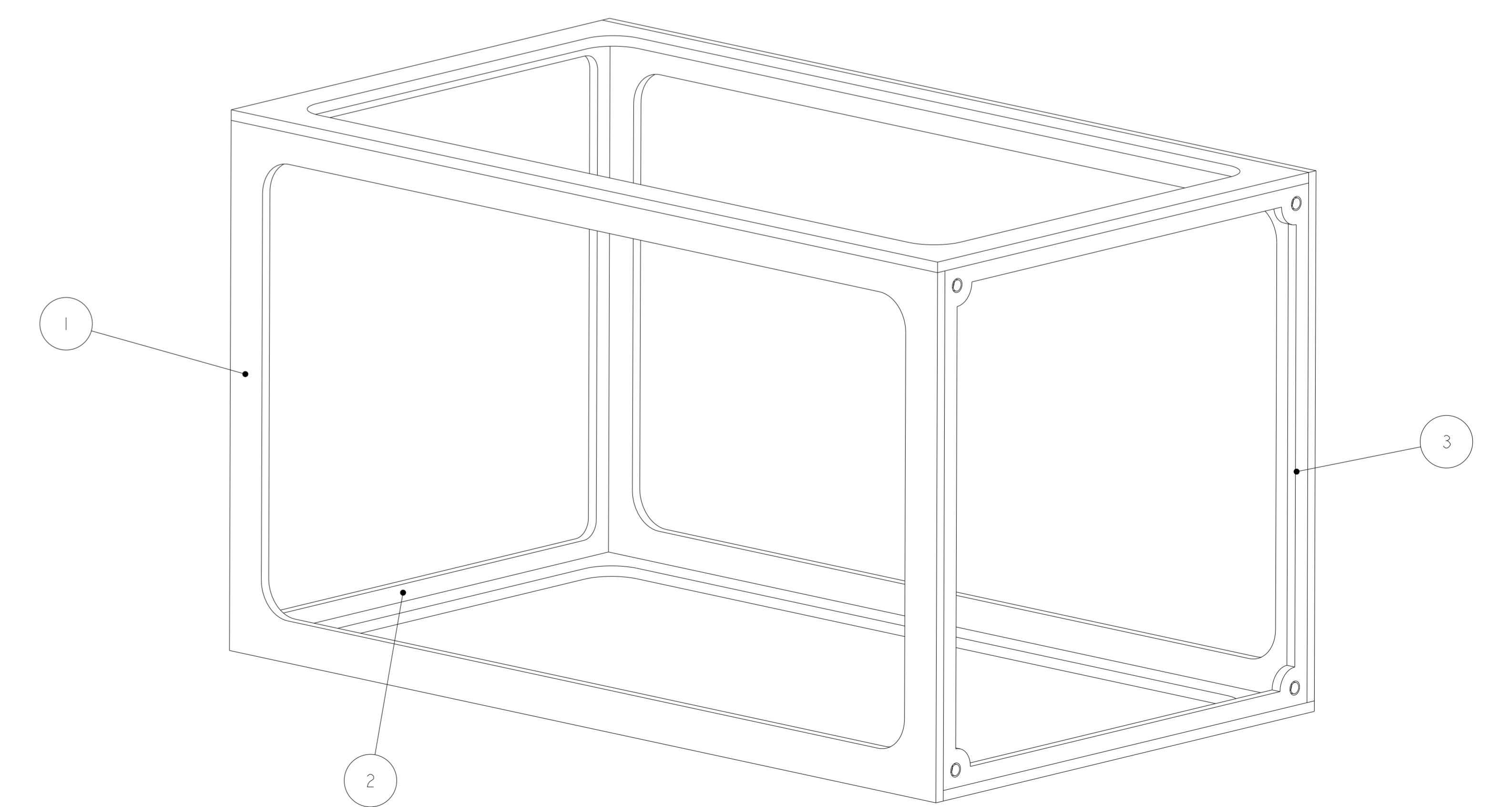

PROJECTION

DO NOT SCALE

REMOVE ALL BURRS AND SHARP EDGES

IF IN DOUBT ASK

DIMENSIONS IN MILLIMETRES UNLESS OTHERWISE STATED

MATERIAL SEE PARTS LIST

DRAWN BY ANDY SMITH

The University of Manchester
 School of Physics & Astronomy
 Design Office
 Schuster Building
 Oxford Road
 Manchester, M13 9PL
 Tele: 0161-275-4062

A 19-Jun-12

B 19-Jul-12

DRAWING ISSUE DATE AND MODIFICATION HISTORY

LINEAR TOLERANCES
 0. = +/- 1.0
 .0 = +/- 0.2
 .00 = +/- 0.1
 .000 = +/- 0.05

ANGULAR TOLERANCES
 .0 = +/- 0.5°
 .0 = +/- 0.25°

FINISH CLEAN

CHECKED BY

SCALE 1:1

TITLE DETECTOR SUPPORT

DRAWING NUMBER
11436-03-A1-NUC